



FHR-21K

Hermetic type rotary compressor
Heating/Cooling Air conditioner uses

R407C
220-240VAC/50Hz

FHR series rotary compressor is designed as per GB/T15765-1995, GB4706.1-1998, GB4706.17-2004, standards, is reference to ASHRAE and ARI standards. FVR series rotary compressors adopt R407C refrigerant.

* GB4706.1-1998, <Household appliances safe standard, Part 1, General standards >
* GB4706.17-2004, <Household appliances safe standard, Motor standard/compressor specific standards>

Specification

■ General

Type	Hermetic Rotary compressor,
Structure of working	Rotary
Refrigerant	R407C
Max.refrigerant charge	1150g
Oil / Max. Oil Feed	RL-32RV/450ml
Surface coating	Amino Baking Enamel coating, semi-gloss, black
Weight	16.0kg
Nominal volume of cylinder	21.3cm ³
Suction pipe diameter (inner)	∅ 12.8mm
Discharge pipe diameter(inner)	∅ 8.1mm

■ Motor performance

Type / Starting	PSC capacitor running
Poles	2poles
Rated voltage	220~240VAC/50Hz
Insulation	Class B
Coil resistance (25°C)	2.36ohm /4.21ohm (main/secondary)
Stall(locked) Current (220V)	36A
Starting voltage range	187V ~ 242V
Running voltage range	198V ~ 242V
Running capacitor	30uF
Waterproof level	D40 (Normal)

■ System performance

Cooling capacity	3580W
Input	1210W
Working current	5.6A
C.O.P	2.96 w/w
Noise	<=65db

Testing condition:

Testing power supply:	220VAC/50Hz		
Evaporating Temperature:	7.2°C	Discharge Temperature:	85°C
Condensing Temperature:	54.4°C	Fan speed:	2m/s
Sub-Cooling Temperature:	46.1°C		
Ambient Temperature:	35°C		
Suction Temperature:	35°C		

■ **Safe parameter**

Gas pressurize	High pressure: 2.9Mpa / Low pressure: 1.6Mpa
Intensity pressure	High pressure: 10.5Mpa / Low pressure: 2.2Mpa
Insulation resistance (cold state)	>= 50M ohm
Electrical strength (cold state)	5mA - AC1800V / 1second passed
Residual water	<= 200mg
Solid residue	<= 100mg
Grounding resistance	<= 0.1 ohm

■ **Limit of uses**

Item	Normal	Max.
Discharge Pressure	<= 2.06Mpa	2.6Mpa
Suction Pressure	0.29 ~ 0.59 Mpa	0.1 ~ 0.69Mpa
Coil temperature	<= 100°C	125°C
Discharge pipe temperature	<= 100°C	115°C

Compressor and accessories

Item	Model Number	Q.T.Y
Compressor	FHR-21K/E	1
Shock absorption mat	/	4
Connecting box	/	1
Connecting box rubber mat	/	1
Fix nut	/	1
Switchboard	B250-150	1
Spring	/	1

Wiring diagram

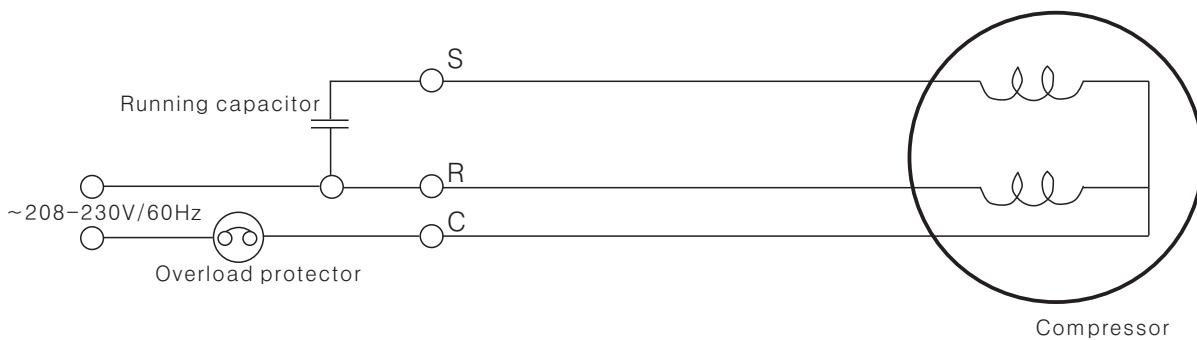

Outline dimensions

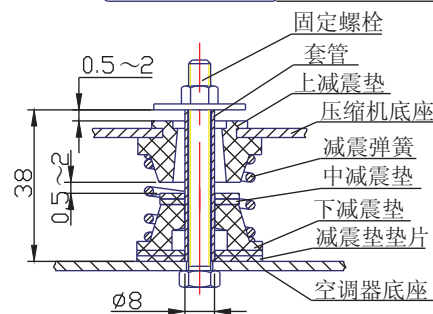
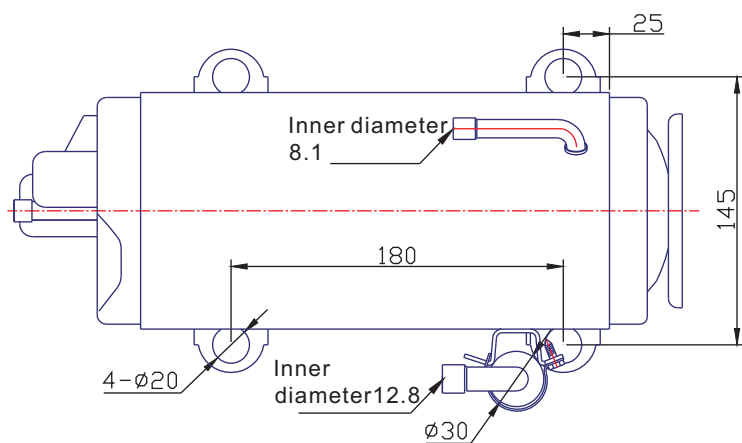
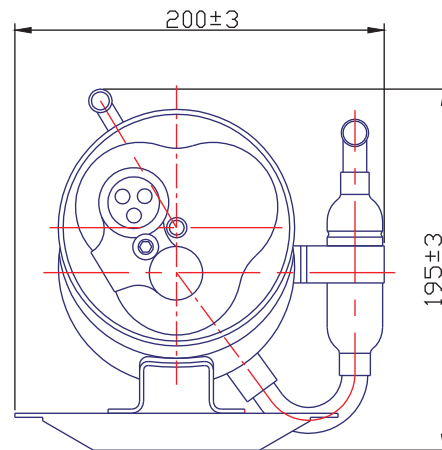
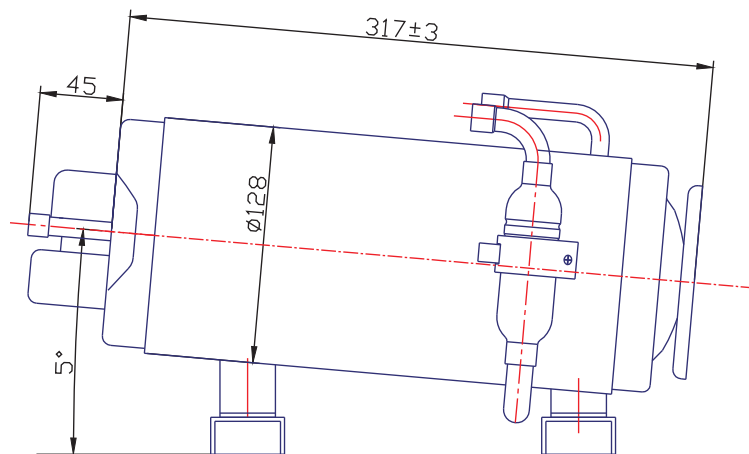

复合减震垫结构

通过调节中减震垫和减震垫垫片来保证两处0.5~2mm的间隙

FHR-19K/21K
FHR-23K